



CONFIDENCE TAKEN TO NEW HEIGHTS.

MANUAL ELECTRIC STACKER

Model : ESTK-15 M3 | Capacity : 1500 kgs



Manual Electric Stacker from 'JAY' are also widely known as Semi Battery Operated Stackers, this stackers is cost effective option for low duty applications of stacking or other operations of loading and unloading of trucks, dies etc. These stackers are easy to use with simple push button operated lifting & lowering operations.

This range of stacker is also available in A.C. version, with flameproof electricals and with customisation as per applications requirements. There are many other compatible accessories available for use with this equipment in variety of applications. This range of equipment from JAY are very useful across all segments of industries.

This equipments are equipped with In-built battery charger for easy charging anywhere any time. It is also equipped with steering wheels which ensures easy manoeuvrability.

KEY FEATURES:

- In-built battery charger
- Steering wheel for easy manoeuvrability
- Robust chassis
- Battery indicator
- Foot guard for operator safety
- Long tiller for effortless operations



Steered wheel with foot guard

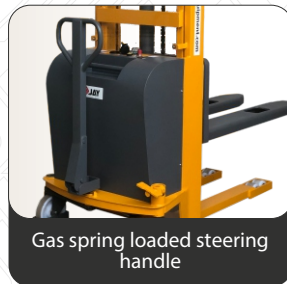

Gas spring loaded steering handle

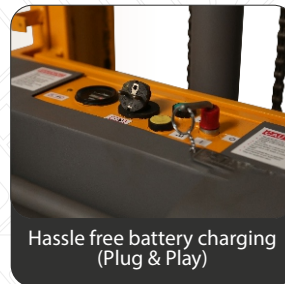

Hassle free battery charging (Plug & Play)



Battery Indicator, Push button control & key switch



LIFT TRUCKS



MANUAL ELECTRIC STACKER

SPECIFICATIONS

			UNIT	ESTK-15 M3
CHARACTERISTICS	Drive type/Power	-	-	Semi-Electric
	Operation type/Driving mode	-	-	Hand
	Rated load capacity	Q	Kg	1500
	Load centre distance	c	mm	600
	Front overhang distance	x	mm	790
	Track/Wheel base	Y	mm	1210
WHEEL CHASIS	Tyre	-	-	Nylon
	Tyre size, rear/drive side	-	mm	Ø180X50
	Tyre size, front/load side	-	mm	Ø82X70
	Wheel number (front/load+rear/drive)	-	-	4+2
	Wheel Track (rear/drive)	b10	mm	720
	Wheel Track (front/load)	b11	mm	380
BASIC DIMENSION	Lift height	h3	mm	3000
	Mast height lowered	h1	mm	2130
	Extended mast height	h4	mm	3090
	Handle height minimum/maximum	h14	mm	885/1165
	Fork lowered height	h13	mm	95
	Overall length	l1	mm	1875
	Length inclusive back of fork	l2	mm	725
	Overall width	b1	mm	830
	Fork dimension	s/e/l	mm	58/180/1150
	Width over fork/Lateral distance of fork	b5	mm	560
	Ground clearance	m2	mm	29
	Aisle width for pallet l-1000 x w-1200 sideways/crossway	Ast	mm	2350
	Aisle width for pallet l-800 x w-1200 lengthway	Ast	mm	2400
	Turning radius	Wa	mm	1900
PERFORMANCE CAPABILITY	Lifting speed - laden/unladen	-	m/s	0.08/0.12
	Lowering speed - laden/unladen	-	m/s	0.12/0.08
	Parking Brake	-	-	Manual
ELECTRIC MOTOR	Lift motor rating S3 15%	-	kW	1.6
	Battery voltage, nominal capacity K5	-	V/Ah	12 / 130
	Battery weight	-	V/A	36
OTHER	Sound pressure level at operator's ear	-	dB (A)	<70
	Turning angle	-	°	100
WEIGHT	Net weight inclusive battery		kg	610

Capacity (At 600mm LC) Kgs.

Mast Type	Lift ht.	Lowered ht.	Extended ht.	ESTK-15 M3
Wide View Mono & Telescopic Mast	(h3)	(h1)	(h4)	
	mm	mm	mm	mm
	1600	2000	2000	1500
	2500	1880	3090	1500
	3000	2130	3590	1100
	3500	2380	4090	650
	4000	2630	4590	450
4200	2730	4790	450	

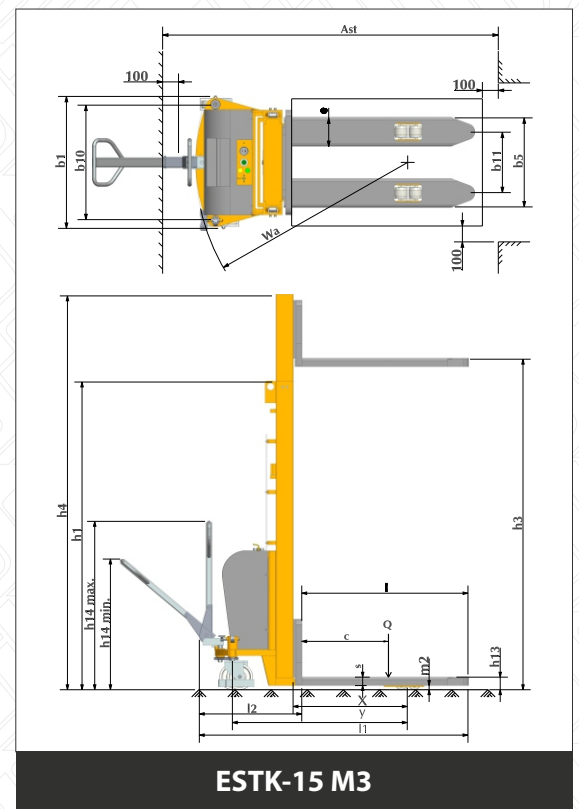

* This specification sheet only provides technical values for the standard equipment only. Customised equipments, Non-standard tyres, different masts, additional equipment, use of accessories, etc. may produce other values

* The values in the table are as per the standard test practices, and actual values may differ as per the site conditions.

* We reserve the rights to technical changes and improvements, without any prior intimations.

MAR-2023

