



## HYDRAULIC PALLET TRUCKS

Model : HPT-25 M8 / HPT-50 M2 | Capacity : 2500 / 5000 Kgs.

Hydraulic Pallet Trucks from 'JAY' are the most economical and cost effective solution for many transport application involving short distances. Its high capacity of two and half tons and easy manoeuvrability in small spaces makes hydraulic pallet truck the perfect warehouse equipment.

Hydraulic pallet trucks are also widely known as hand pallet trucks, these are the ideal equipment for handling and movement of palletised loads, and can also be customised as long or short fork lengths, and it is widely used in factories, warehouses and many other areas. This range of equipment from JAY are very useful across all segments of industries.



Three positions operations

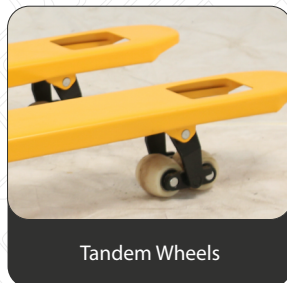

Tandem Wheels

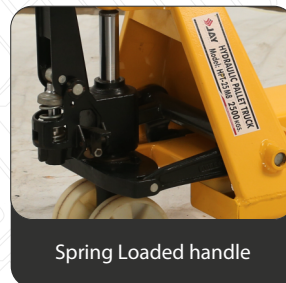

Spring Loaded handle

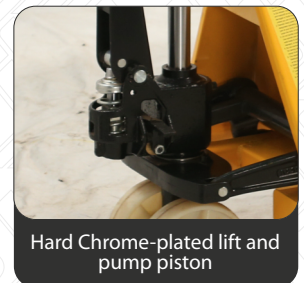

Hard Chrome-plated lift and pump piston

THE PROVEN PERFORMERS



# LIFT TRUCKS



## HYDRAULIC PALLET TRUCKS

### SPECIFICATIONS

		UNIT	HPT-25 M8	HPT-50 M8	HPT-25 SS M1	HPT-25 SC M8	
CHARACTERISTICS	Drive type/Power	-	-	Manual	Manual	Manual	Manual
	Rated load capacity	Q	Kg	2500	5000	2500	2500
	Load centre distance	c	mm	600	600	600	600
	Track/Wheel base	Y	mm	1190	1190	1190	1190
WHEEL CHASSIS	Tyre	-	-	Nylon / Polyurethane	Nylon / Polyurethane	Nylon / Polyurethane	Nylon / Polyurethane
	Tyre size, rear/drive side	-	mm	Ø180X50	Ø180X50	Ø180X50	Ø180X50
	Tyre size, front/load side	-	mm	Ø82X70	Ø82X70	Ø80X70	Ø65X70
	Wheel number (front/load+rear/drive)	-	-	4+2	2+2	4+2	4+2
BASIC DIMENSION	Lift height	h3	mm	195	195	195	195
	Chassis height lowered	h1	mm	435	435	435	435
	Handle height	h14	mm	1250	1250	1250	1250
	Fork lowered height	h13	mm	85	85	85	85
	Overall length	l1	mm	1540	1540	1540	1540
	Overall width	b1	mm	550/685	550/685	550/685	550
	Aisle width for pallet I-1000 x w-1200 sideway/crossway	Ast	mm	1550	1550	1550	1550
	Aisle width for pallet I-800 x w-1200 lengthway	Ast	mm	1750	1750	1750	1750
WEIGHT	Turning radius	Wa	mm	1390	1390	1390	1390
	Net weight inclusive battery		kg	85/95	120/130	82/92	125

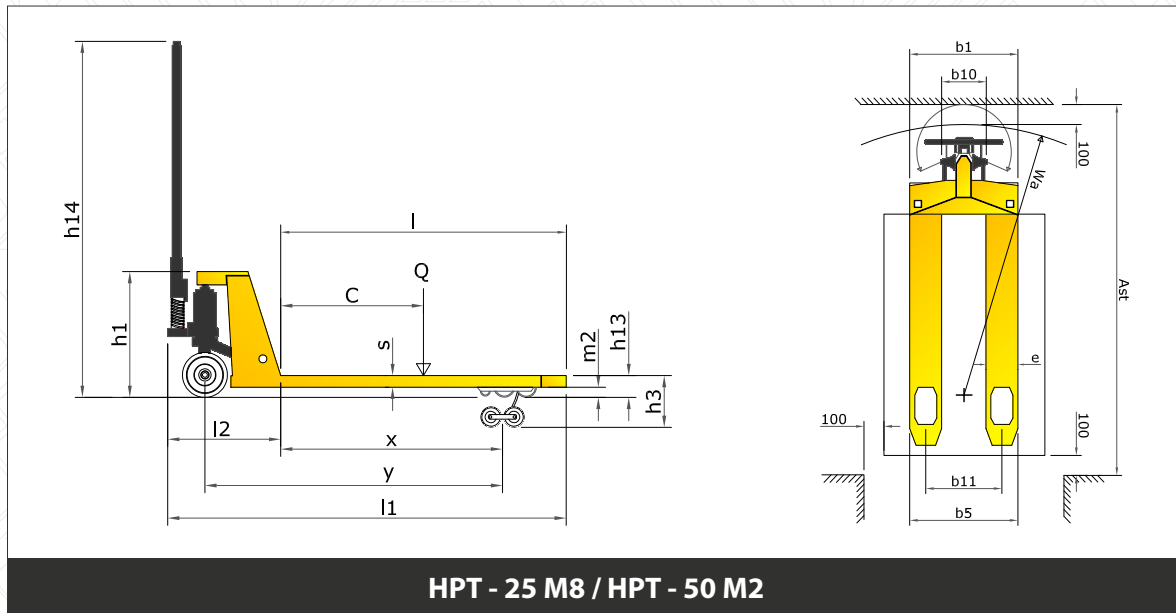

\* This specification sheet only provides technical values for the standard equipment only. Customised equipments, Non-standard tyres, different masts, additional equipment, use of accessories, etc. may produce other values  
 \* The values in the table are as per the standard test practices, and actual values may differ as per the site conditions.  
 \* We reserve the rights to technical changes and improvements, without any prior intimations.

AUG-2023

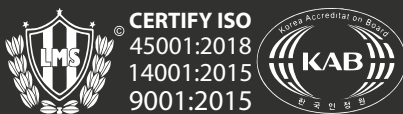

**JAY EQUIPMENT & SYSTEMS PVT. LTD.**  
 +91 9146054222/23/24/25  
 sales@jayequipment.com  
 www.jayequipment.com



CONTACT US